



The Leader in Pharmaceutical Printing, Laser Drilling & Vision Inspection Machinery



For Tablets, Caplets, LCT's, Softgels & Hard Shell Capsules
Output Up to 60,000 Products / hour



VIP Printer

One or Two-Sided Rotogravure Printing
Single-Lane Carrier Link Feed System

VIP Printer

Rotogravure Printing System for Tablets & Capsules

Precision rotogravure printing system for pharmaceutical and confectionary products. Features a single-lane carrier timing belt feed system that exposes both sides of product for inspection and ink printing. Effortless continuous operation with minimal user interaction or downtime. Requires only compressed air and power for operation.

Features

- Single-lane carrier link system
- Safety enclosure with interlocked doors
- Servo based motion with optical encoder position feedback
- Carrier timing belt with precision machined pockets
- Tool-free installation of carrier links
- Adjustable hopper assembly for quick changeover between products
- Patented hopper air-assist feature & clean air filtration system
- Articulated swing arm with 17" touch-screen HMI
- User friendly interface
- Programmable settings for up to 50 products
- Portable with a small footprint
- Low maintenance cost
- Worldwide customer support
- Toolkit included

Capabilities

- Output Up to 60,000 / Hour
- Single or Double Sided Printing with independent graphics for each side
- Single Sided marking using time proven rotogravure printing
- Ability to print alpha-numeric text or graphic logos
- Ability to print with solvent or water based ink solutions
- Ability to print in multiple ink colors

Options

- Vision inspection with vacuum-based single product rejection
- OPC-UA Server Gateway
- HMI screen text translated and displayed in language of choice
- Secure remote support capabilities
- Auto-backup of product settings

Safety & Regulatory Compliance

- **cGMP for Pharmaceuticals:**
- **FDA 21 CFR Compliance:**
 - Part 210
 - Part 211
 - Part 11
- **CE Compliant**
- **NFPA 79**
- **IEC / EN 60204-1**
- **ISO 13849-1**
- **CRC, c 870**
- **CDRH Compliant**

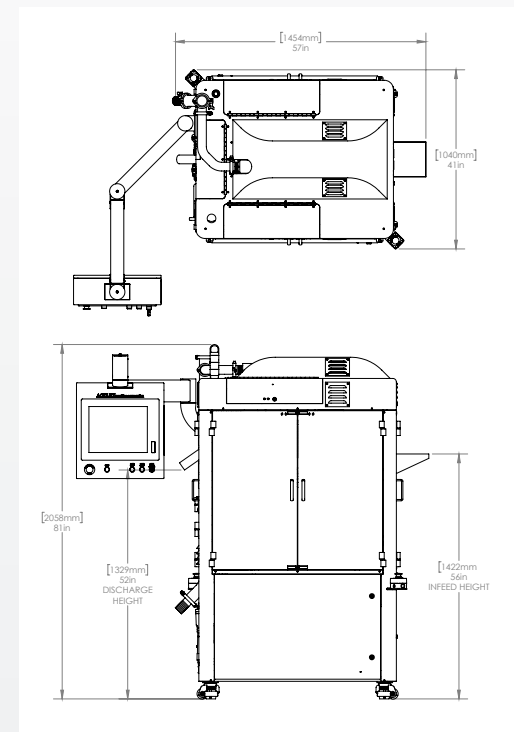

Specifications

Machine Dimensions:

Height 81" (2057 mm) x Width 58" (1473 mm) x Depth 41" (1041 mm)

Infed Height: 56" (1422 mm)

Discharge Height: 52.4" (1331 mm)

Weight: 2050 Lbs. (930 kg)

Power Requirement:

208-240 VAC / 50-60 Hz /

1 Phase, 25 Amp

Compressed Air:

85 PSI (6 Bar) @ 45 sCFM (76.5 m3/hr.)



Proudly Made in the USA